



Cumbres & Toltec Scenic Railroad Junior Engineer Guide

Who are the Friends and what do they do?

The Friends of the Cumbres & Toltec Scenic Railroad is a nonprofit organization whose goal is to preserve the history and legacy of the Denver & Rio Grande Narrow Gauge Railroad along the 64-mile National Historic Landmark Cumbres & Toltec Scenic Railroad.

Preservation: The Friends work to preserve narrow gauge history through photos, videos, and written documents.

Interpretation: The Friends share railroad history with the public through interpretive exhibits such as signage, exhibits, and oral storytelling. The Docents onboard the train are volunteers who help share the history of the railroad with you!

Restoration: Volunteers attend annual work sessions to participate in historically accurate restoration of equipment and structures along the line.

You can be a part of preserving a National Historic Landmark by becoming a Friends' member and donating time or money.

friendsofcumbrestoltec.org



Prepared by the Friends of the Cumbres & Toltec Historic Interpretation Committee.

Illustrations: Frank Martindell, Melissa Sellers, Kathleen Walser, Sandra Engs, Cori Schrader, Nolan Gloyd

©2023 Friends of the Cumbres & Toltec Scenic Railroad, Inc.

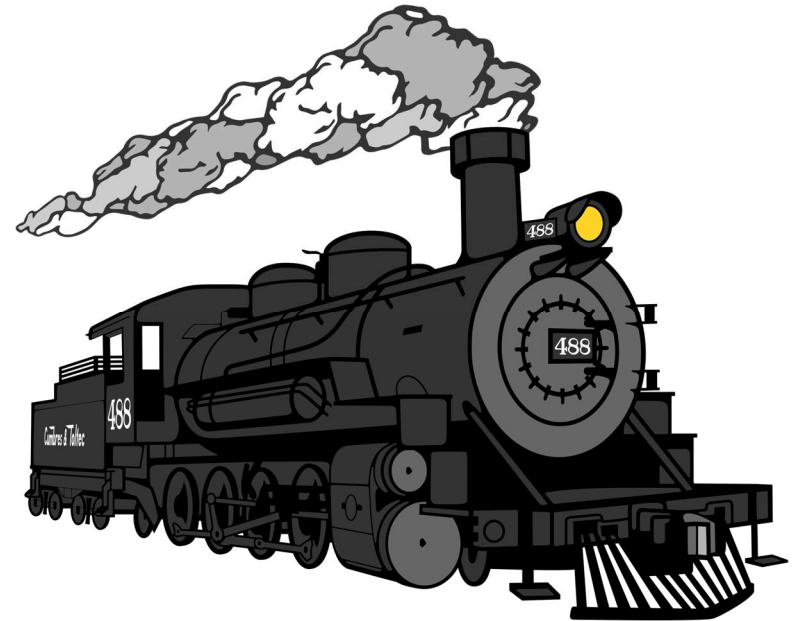

Welcome to the historic San Juan Extension of the Denver & Rio Grande Railroad! Built in 1880, this roughly 200-mile line provided additional transportation for mining towns in Western Colorado. However, as automobiles became more widely used, the need for the railroad dwindled. By 1968, the Denver & Rio Grande Western ceased operations on this portion of the line. In 1970, the states of Colorado and New Mexico jointly purchased a 64-mile section of the San Juan Extension. After the purchase, volunteers stepped in and helped the states prepare the new Cumbres & Toltec Scenic Railroad for passengers to enjoy as America's foremost moving museum.

Presented by the Friends of The Cumbres & Toltec Scenic Railroad, Inc.



Completing your Guide Book

Welcome to the Junior Engineer Program of the Cumbres & Toltec Scenic Railroad! To earn your Junior Engineer Certificate, complete the number of activities listed below for your age group.

Age	5 — 7	8 — 10	11 and above
Number of Activities	6	9	12



Make sure you look through this book before you start your ride. Some activities have you looking for landmarks on your trip.

When you have completed your activities, ask a Docent (usually found in the open-air car called a Gondola) to certify you as a Cumbres & Toltec Scenic Railroad Junior Engineer!

If you are unable to locate a Docent, you can take pictures of your completed pages and email them to education@fctsr.org and we will send your certification.

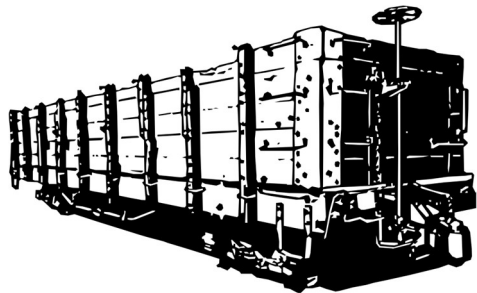

MY MEMORIES

Use this page to write or draw things you want to remember or learn more about.

Whistle Signals

Train whistles are very important to the railroad. Whistles are used by railroad employees to communicate with each other and to warn people about approaching trains.

Listen for the whistle and see if you can determine what the train engineer is communicating. Put an x next to each signal you hear.

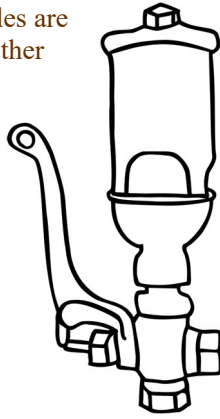

Whistle Signals

Short sound: ●
Long sound: —

- Apply brakes / Stop
- Release brakes / Answer to signal not otherwise listed
- When stopped, back up / When moving, stop at next station
- Request for signals (asking for communication)
- Many short sounds together - used for an emergency or to warn people and animals to get off the tracks if in immediate danger
- Approaching station
- — Proceed
- — — — Trainman — return from west or south / 5 minute departure warning
- — — — — Trainman — return from east or north
- ● Warning (especially where view may be obscured)
- — ● Approaching meeting point of trains
- — ● — Approaching public road (repeated until engine is through crossing)
- ●●● Trainman — protect rear of train
- — Trainman — protect front of train

Draw your Steam Locomotive



Train engines have a **Builder's Plate**. It is much like a birth certificate. See if you can locate your locomotive's builder's plate, which is usually located over the cylinders (see Locomotive Parts activity) on the engineer's side.

Who made it? _____

What year was it built? _____

Let's figure out how old the locomotive is this year.













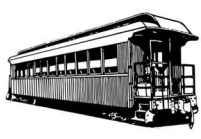
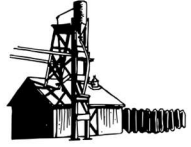

What year is it now? _____

Subtract what year it was built: — _____

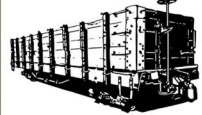
How old is the locomotive? _____

How old are you? _____

Scavenger Hunt

Water Standpipe 	Section House 	Passenger Car 	Sand House 
Tunnel 	Coal Tipple 	Bridge 	Water Tank 
Locomotive 	Gondola 	Stockyard / Pens 	Boxcar 
Engine Shop / Roundhouse 	Rotary Snow Plow 	Milepost 	Depot 

Good engineers are always aware of their surroundings.
Mark the items above that you see on your trip.

Classifying Engines — Whyte Notation

The Whyte Notation System uses the number of wheels in three groups to determine locomotive classification type with a number and a name.

To classify the locomotives:

1. Count the leading (pilot) wheels.
2. Count the driving wheels.
3. Count the trailing wheels.

Three types of steam locomotives you may see around the railyard:

Locomotive 168 is a **4-6-0** “Ten-Wheeler” type.

Locomotive 315 is a **2-8-0** “Consolidation” type.

Most locomotives seen at the C&TS are **2-8-2** “Mikado” types.

For each engine below, circle the locomotive type.

Don't forget to count the wheels on both sides of the locomotive.

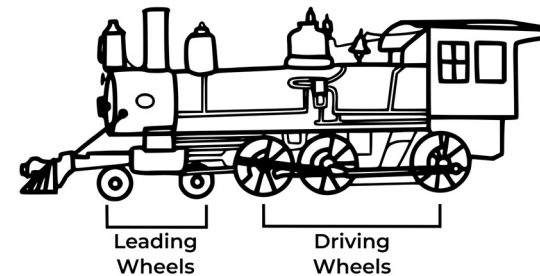

- 4-6-0 “Ten-Wheeler”
- 2-8-0 “Consolidation”
- 2-8-2 “Mikado”

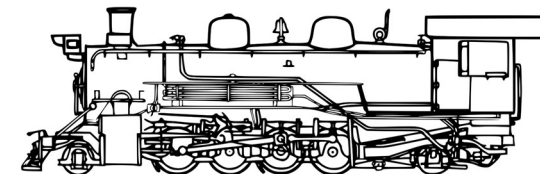

- 4-6-0 “Ten-Wheeler”
- 2-8-0 “Consolidation”
- 2-8-2 “Mikado”

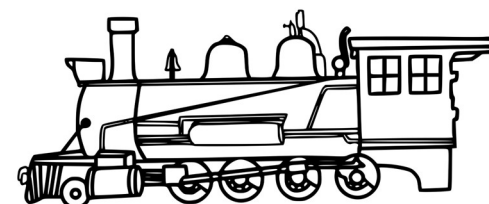

- 4-6-0 “Ten-Wheeler”
- 2-8-0 “Consolidation”
- 2-8-2 “Mikado”

Role of Railroad Workers

Draw a line between the railroad workers and their jobs.

Engineer	Gives passengers information on the train ride. Answers questions.
Track Crew	Responsible for producing steam. Shovels coal, stokes the fire, ensures water in boiler.
Dispatcher	Manages crew activities; is in charge of the train. Checks tickets.
Fireman	Performs train inspection & drives the train.
Brakeman	Responsible for maintenance of the track.
Conductor	Precedes or follows the train; watches for fires or other hazards.
Docent	Coordinates the movement of all trains between stations.
Speeder Car Worker	Historically, responsible for slowing down and stopping trains. Aligns switches for trains to change tracks.

Use the items from the scavenger hunt to fill in the blanks.

Pick up your tickets at the _____ .

The train takes on water using a _____ or a _____ .

The _____ is where a train used to load up on coal for the trip. Now a front loader is used.

The cars of a train are pulled by the _____ .

You can ride in a _____ or in a _____ on this train trip.

To provide traction for the train, the engine must be loaded with something. The _____ is a place it is found.

The _____ can be used in winter to make the track usable.

A foreman was responsible for maintaining approximately 10 miles of track surrounding the _____ where he lived with his family.

ALL ABOARD...

Draw a ★ at the location where you began your train ride.

Circle locations where the train crosses the border between Colorado and New Mexico.

How many times does the train cross the border in one trip between Chama and Antonito? _____

Underline the name of each location where you got off the train.

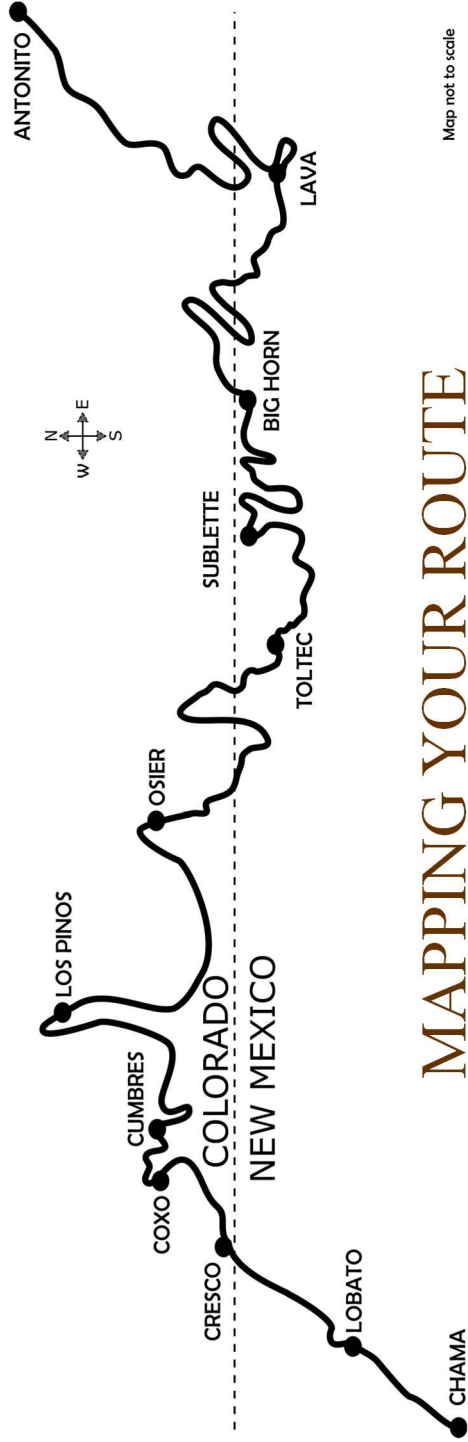

Map not to scale

MAPPING YOUR ROUTE

How Does a Train Turn Around?

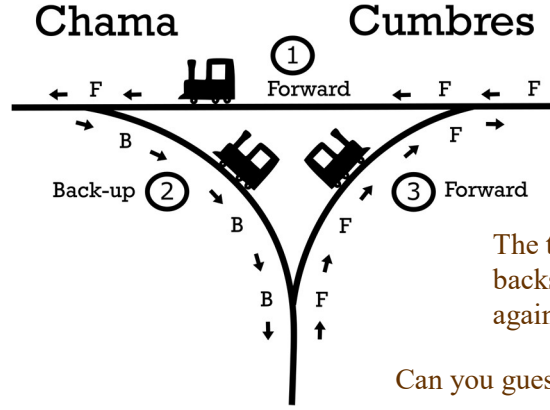

The most common way to turn a train around is on a **Wye**, like in Chama and Cumbres.

The train travels forward, then backs up, then travels forward again, as shown in the drawing.

Can you guess why it is called a WYE?

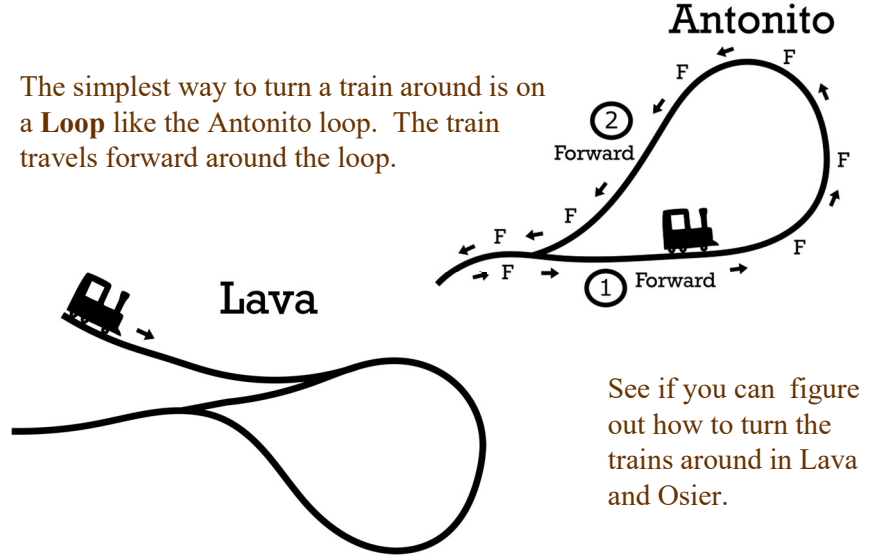

The simplest way to turn a train around is on a **Loop** like the Antonito loop. The train travels forward around the loop.

See if you can figure out how to turn the trains around in Lava and Osier.

Draw arrows to show how to turn the train around. Write F when the train is going forward and B when the train is backing up. Label as steps 1,2,3 as needed.

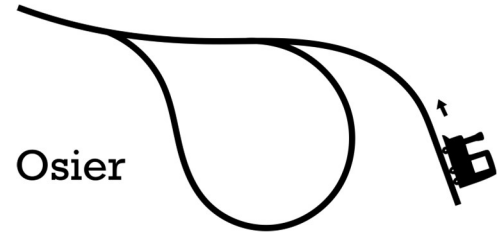

Bridging the Gap

Near Chama, the train crosses a **truss**, a bridge that uses a series of interconnected triangles to provide strength and support. A truss can span large distances. Each end of the truss is held up by **piers**. Temporary supports, called **falsework**, hold up the truss while it is being built.

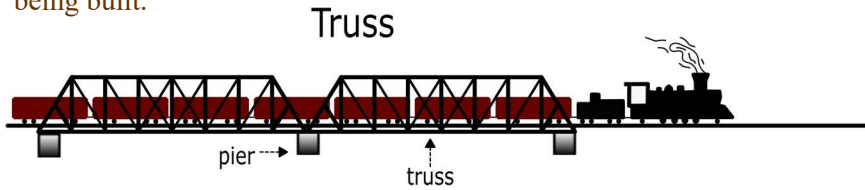

A **trestle** is another kind of railroad bridge. It is easier to build. **Girders** run horizontally, underneath the track. **Bents** are triangular supports that hold up the girders.

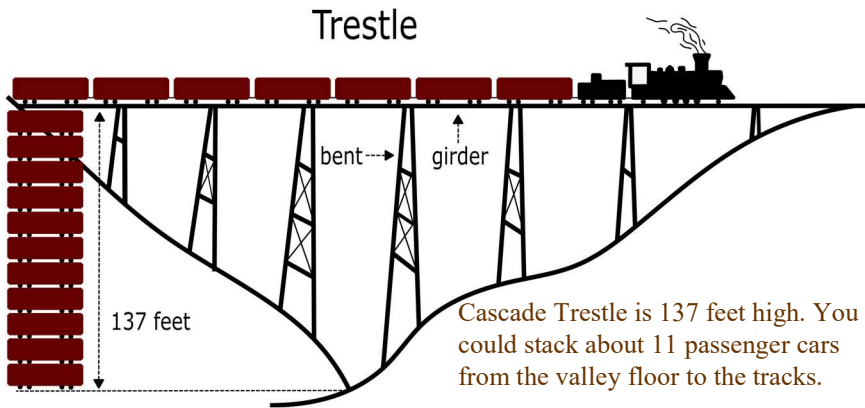

Sometimes, two engines are used to pull a long train up the steep grade between Chama and Cumbres Pass. Due to weight limits at **Lobato Trestle**, only one engine can cross at a time.

Watch for Trusses and Trestles on your trip. How many did you see?

Trusses _____ Trestles _____

Trains were important for getting goods from one place to another. Find items that were transported by train.

H	S	V	V	R	C	R	T	D	C	A	N	D	Y	N	GOLD	BEANS	SHEEP
M	O	X	V	T	E	L	L	U	X	W	F	X	C	E	HORSES	CANDY	SILVER
A	X	R	I	J	E	V	O	W	Q	C	Z	D	E	W	LUMBER	CLOTH	TOOLS
I	Z	U	S	L	O	W	V	T	Q	O	X	A	R	S	MAIL	COAL	TOYS
L	R	Q	P	E	E	H	E	I	H	A	P	E	Q	P	NEWSPAPERS	FRUIT	WHEAT
F	A	O	H	G	S	T	O	Y	S	L	B	R	M	A			
K	E	T	I	G	P	I	N	T	O	M	P	U	S	P			
P	A	R	F	I	W	V	L	H	U	L	I	T	M	E			
R	O	I	L	N	S	H	J	L	V	W	P	I	P	R			
B	L	X	G	B	J	E	N	W	D	E	N	L	S				
G	O	L	D	S	R	E	U	A	J	V	S	R	O	N			
W	S	H	E	E	P	A	A	N	T	V	W	U	W	H			
N	H	P	I	C	H	I	T	N	U	T	S	F	S	P			
T	O	O	L	S	K	P	C	Y	S	I	L	V	E	R			

Communities Along the Railroad

Many towns developed along the railroad, much like large towns today are developed along interstate highways.

Chama and Antonito are both railroad towns that flourished because of the railroad. Smaller communities developed along the railroad, especially where the train stopped to take on water. Without the railroad, the places listed on the map above would likely not exist.

Put a ✓ next to the locations where you see a water tank or water standpipe (see scavenger hunt page for images):

- Chama
- Lobato
- Cresco
- Coxo
- Cumbres
- Los Pinos
- Osier
- Toltec
- Sublette
- Big Horn
- Lava
- Antonito

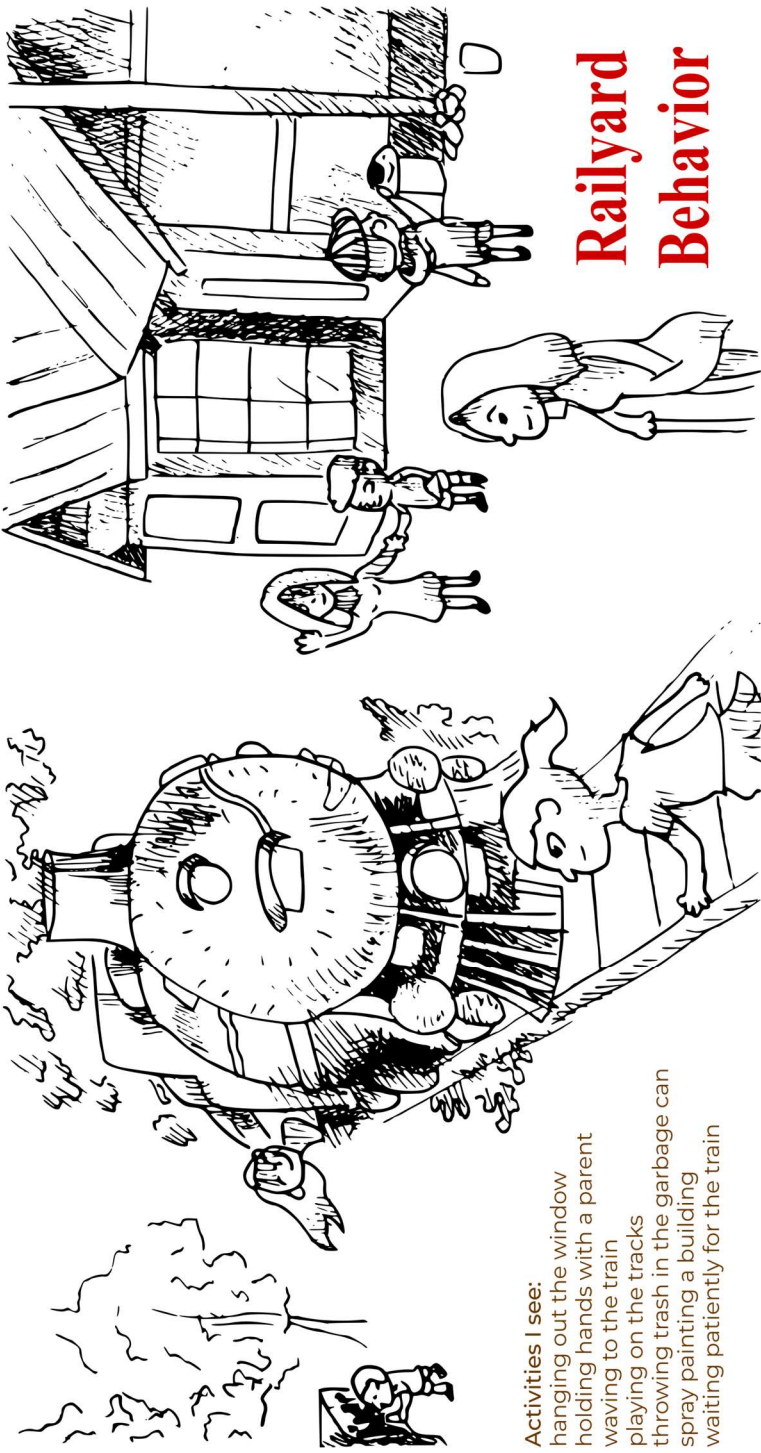

Railyard Behavior

Activities I see:
 hanging out the window
 holding hands with a parent
 waving to the train
 playing on the tracks
 throwing trash in the garbage can
 spray painting a building
 waiting patiently for the train

Being safe around trains is very important. See if you can find activities that people should and should not be doing. **Circle the people who are behaving responsibly. Cross out the people who are misbehaving.**

Learning about the Cumbres and Toltec

Use the code below to learn about the railroad.

♡ ☺ 🎵 🙌 📺 👁️ 🍀 📱 🌐 ✈️ ➔ 📧 ▼ ⊗ ★ 📞 ✂️ ⌚ 💧 🌙 ◆
 A B C D E F G H I J K L M N O P Q R S T U V W X Y Z

1. The Cumbres & Toltec Scenic Railroad is a _____ Landmark.
 ✈️ ♡ ★ 👁️ ➔ ✈️ ♡ 📱 👁️ ⊗ ★ ➔ ▼ 👁️ ⌚

2. It is 64 miles long, and is the _____ and _____ steam-powered railroad in America.
 📱 👁️ 📺 🍀 🎵 ⊗ ★

3. The train travels through two _____.

★ 📞 ✈️ ✈️ 🎵 📱 ⊗



SCENIC RAILROAD

The Cumbres & Toltec logo incorporates historical elements of the scenic railroad.

The flags on either side of the engine represent the states of Colorado and New Mexico, who jointly purchased the railroad.

Engine number 483 was the first working engine owned by the Cumbres and Toltec Scenic Railroad.

The mountains in the background represent the Rocky Mountains, which you travel through when riding the train.

What part of the logo do you like best and why?

Locomotive Parts

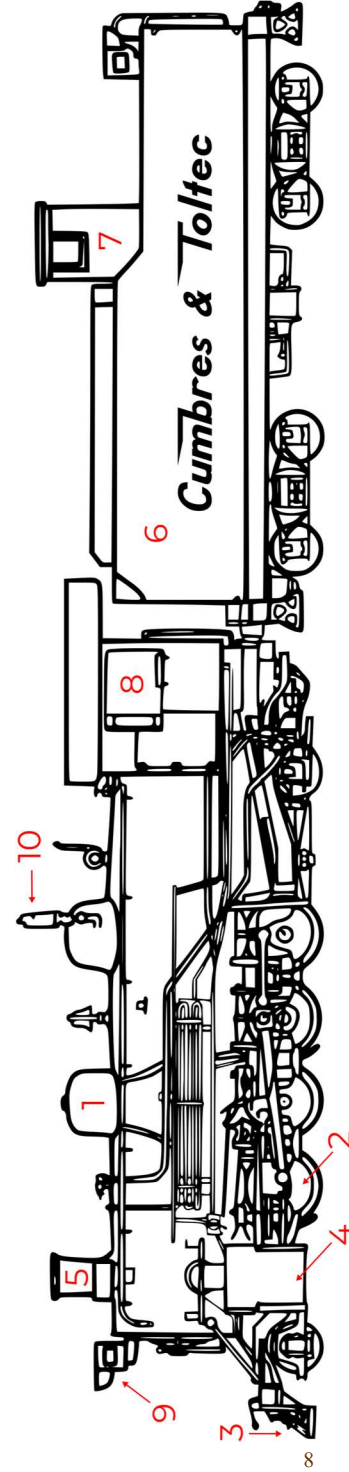

Write the number next to the description of the locomotive part.

- ___ **Cab** - engineer and fireman run the train from here ___ **Headlight** - lights up the track and makes the train more visible
- ___ **Cow Catcher** - prevents objects from going under train ___ **Sand Dome** - holds sand to drop on the track to improve traction
- ___ **Cylinders** - movement in these creates the chuffing sound ___ **Smoke Stack** - acts as exhaust, releases smoke and excess steam
- ___ **Doghouse** - shelter for brakeman ___ **Steam Whistle** - connected to steam dome, used for signalling
- ___ **Drive Wheels** - push against the rails to move train forward ___ **Tender** - where coal and water are stored



CERTIFICATE
OF
JUNIOR ENGINEER



AWARDED TO _____

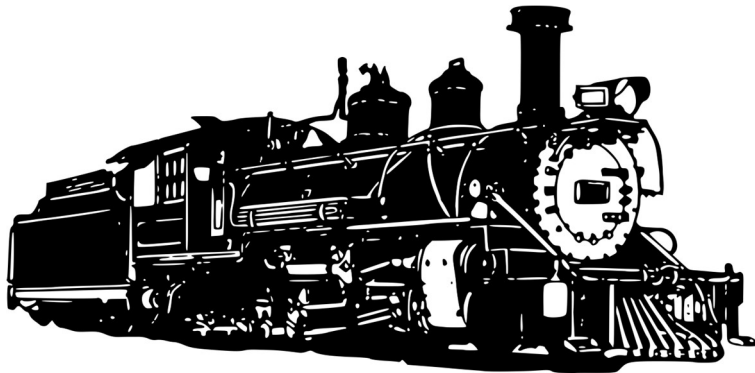

Friends of the Cumbres & Toltec
Scenic Railroad